

Tri-Axis Motion Detection Using MEMS For Unwired Mouse Navigation System In The Future Generation Machines

Syed Amjed Ali¹, Raees Ahmad², Moeenuddin Ansari³

^{1,2,3}Asst Professor ,Theem College of Engineering boisar-401501

Abstract— We constructed an interface system that would allow a similarly paralyzed user to interact with a computer with almost full functional capability. That is, the system operates as a mouse initially, but the user has the ability to toggle in and out of a keyboard mode allowing the entry of text. This is achieved by using the control from a single eye, tracking the position of the pupil for direction, and using blinking as an input. As detection of eye motion proved too challenging, we built an accelerometer based tilt detector to determine head motion, so that, although not as applicable in this particular case, it might be use by a quadriplegic individual

The system uses accelerometers to detect the user's head tilt in order to direct mouse movement on the monitor. The clicking of the mouse is activated by the user's eye blinking through a sensor. The keyboard function is implemented by allowing the user to scroll through letters with head tilt and with eye blinking as the selection mechanism.

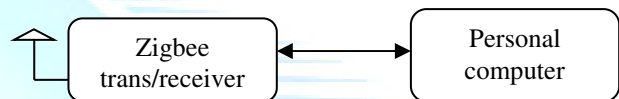

Cursor can be moved with the help of head movements. 3-Axis Accelerometer will send the movement direction to Microcontroller. Microcontroller then passes the actual information to encoder. Information encoded then sends using TX Zigbee receiver will decode the received information. Microcontroller sends to PC through RS232 cable. It will perform the operation. Same operation for selecting any documents with the help of eye blink

A. Overview of the System

Easy Input is a head-controlled keyboard and mouse input device for paralyzed users. This study describes the motivation and the design considerations of an economical head-operated computer mouse. In addition it focuses on the invention of a head-operated computer mouse that employs tilt sensors placed in the headset to determine head position and to function as simple head operated computer mouse. One tilt sensor detects the lateral head motion to drive the left or right displacement of the mouse

Micro Controller (ARM7) FAMILY:

The Thumb set's 16-bit instruction length permits it to approach double the density of traditional ARM code whereas retentive most of the ARM's performance advantage over a regular 16-bit processor victimization 16-bit registers. Typically {this can be} often possible as a results of Thumb code operates on an analogous 32-bit register set as ARM code.

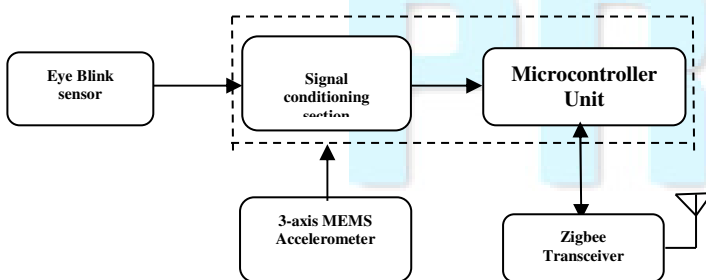
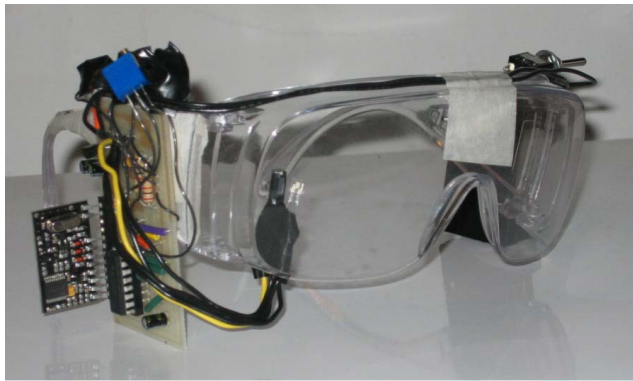

Figure 1. Module wise Block Diagram

E. Eye blink sensors



F. This switch is activated when the user blinks their eye. It allows individuals to operate electronic equipment like communication aids and environmental controls hands-free. Each blink of the eye is detected by an infrared sensor, which is mounted on dummy spectacle frames.

G. The eye blink switch can be set up to operate on either eye and may be worn over normal glasses. The sensitivity of the switch can be adjusted to the users needs and involuntary blinks are ignored. The sensor is connected to a hand-held control unit with a rechargeable battery

H. MEMS

The figure 2 shown the how the MEMS sensor is interconnect with the microcontroller unit the MEMS sensor function it is supported for the 3 axis direction

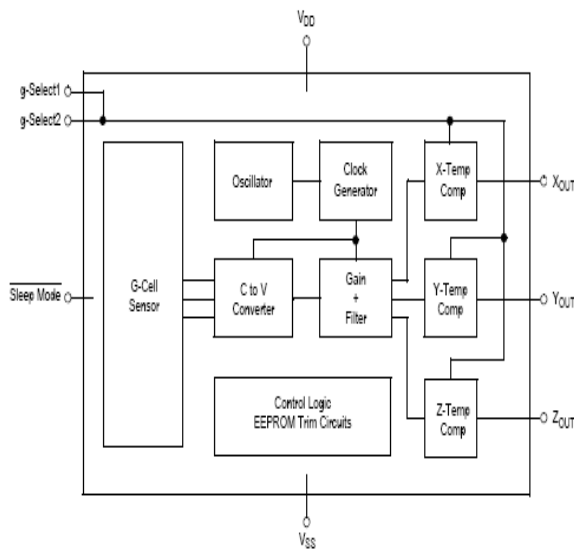

Figure 2. Simplified Accelerometer Functional Block Diagram

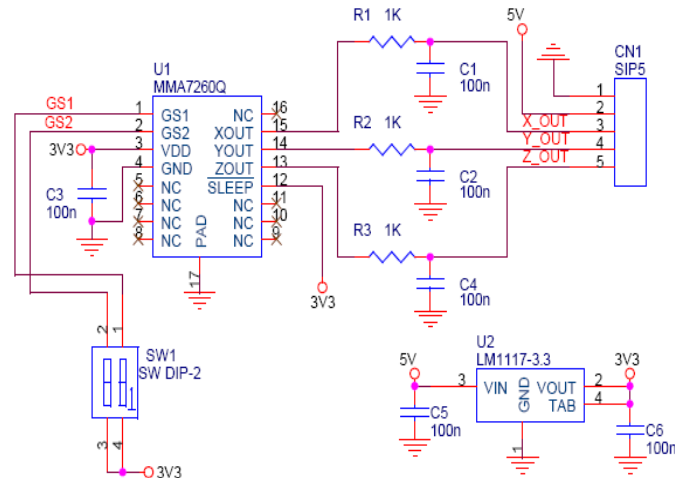

Figure 3.circuit diagram for MEMS

a)Mems features

- Selectable Sensitivity (1.5g/2g/4g/6g)
- Low Current Consumption: 500 iA
- Sleep Mode: 3 iA
- Low Voltage Operation: 2.2 V – 3.6 V
- 6mm x 6mm x 1.45mm QFN
- High Sensitivity (800 mV/g @ 1.5g)
- Fast Turn On Time
- Integral Signal Conditioning with Low Pass Filter
- Robust Design, High Shocks Survivability
- Pb-Free Terminations
- Environmentally Preferred Package
- Low Cost

I. D.voice recognition

Voice recognition kit processes voice analysis, recognition process and system control functions 40 isolated voice word voice recognition system can be composed of external micro-phone, Keyboard, 64K SRAM and some other components Here we are using HM2007 IC for voice recognition

a) Feature of voice

- Single chip voice recognition CMOS LSI with 5V power supply
- Speaker dependent isolates-word recognition system
- External 64K SRAM can be connected directly

- Maximum 40 words can be recognized for one chip
- Maximum 1.92 sec of word can be recognized
- Multiple chip recognition is possible
- Microphone can be connected directly
- Two control mode is supported
 - Manual mode
 - CPU mode
- Response time: less then 300 ms

b) Functional modes

Manual Mode

- Keypad, SRAM and other components can be connected HM2007 to build simple recognition system
- Type of SRAM can be used is 8K-byte memory

Power on mode

- When the power is on HM2007 will starts initialization process
- If WAIT pin is 'L', HM2007 will do the memory check to see whether 8K-byte SRAM is perfect/not
- If WAIT pin is 'H', HM2007 will skip the memory check process
- After initial process is done, HM2007 will then moves into recognition mode

Recognition mode

- RDY is set to low and HM2007 is ready to accept the voice input to be recognized
- When the voice input is detected, the RDY will return to high and HM2007 begins its recognition process

c) Classification of speech recognition

(1) Speaker Dependand

Speaker dependent systems are trained by the individual who will be using the system. These systems are capable of achieving a high command count and better than 95% accuracy for word recognition. The drawback to this approach is the system only responds accurately only to the individual who trained the system. This is the most common approach employed in software for personal computers.

(2) Speaker Independent

Speaker independent is a system trained to respond to a word regardless of who speaks. Therefore the system must respond to a large variety of speech patterns, inflections and enunciation's of the target word. The command word count is usually lower than the speaker dependent however high accuracy can still be maintained within processing limits. Industrial requirements more often need speaker independent voice systems, such as the AT&T system used in the telephone systems

d) Module view

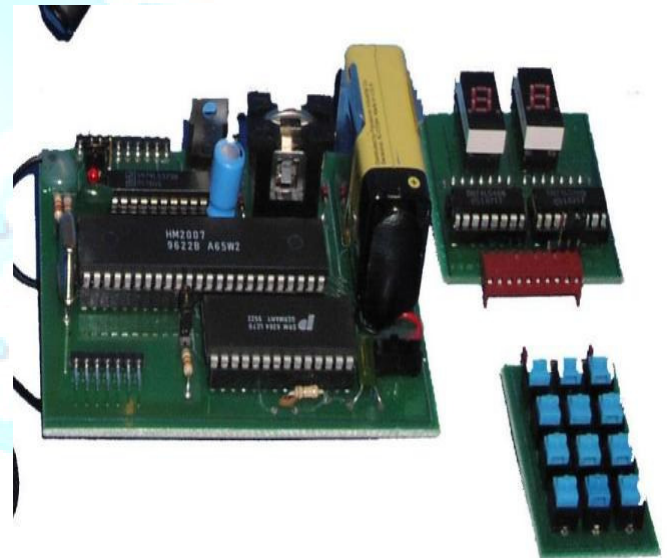
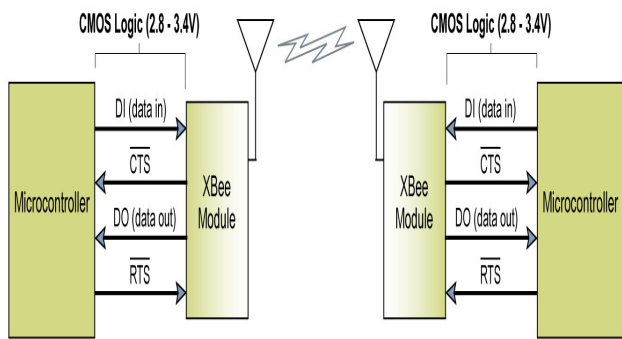

Figure 4. Speech recognition module overview

E) wireless communication

The XBee and XBee-PRO OEM RF Modules were engineered to meet IEEE 802.15.4 standards and support the unique needs of low-cost, low-power wireless sensor networks. The modules require minimal power and provide reliable delivery of data between devices. The modules operate within the ISM 2.4 GHz frequency band and are pin-for-pin compatible with each other. The XBee®/XBee-PRO OEM RF Modules interface to a host device through a logic-level asynchronous serial port. Through its serial port, the module can communicate with any logic and voltage compatible UART; or through a level translator to any serial device (For example: Through a Digit proprietary RS-232 or USB interface board).



F) Flow chart

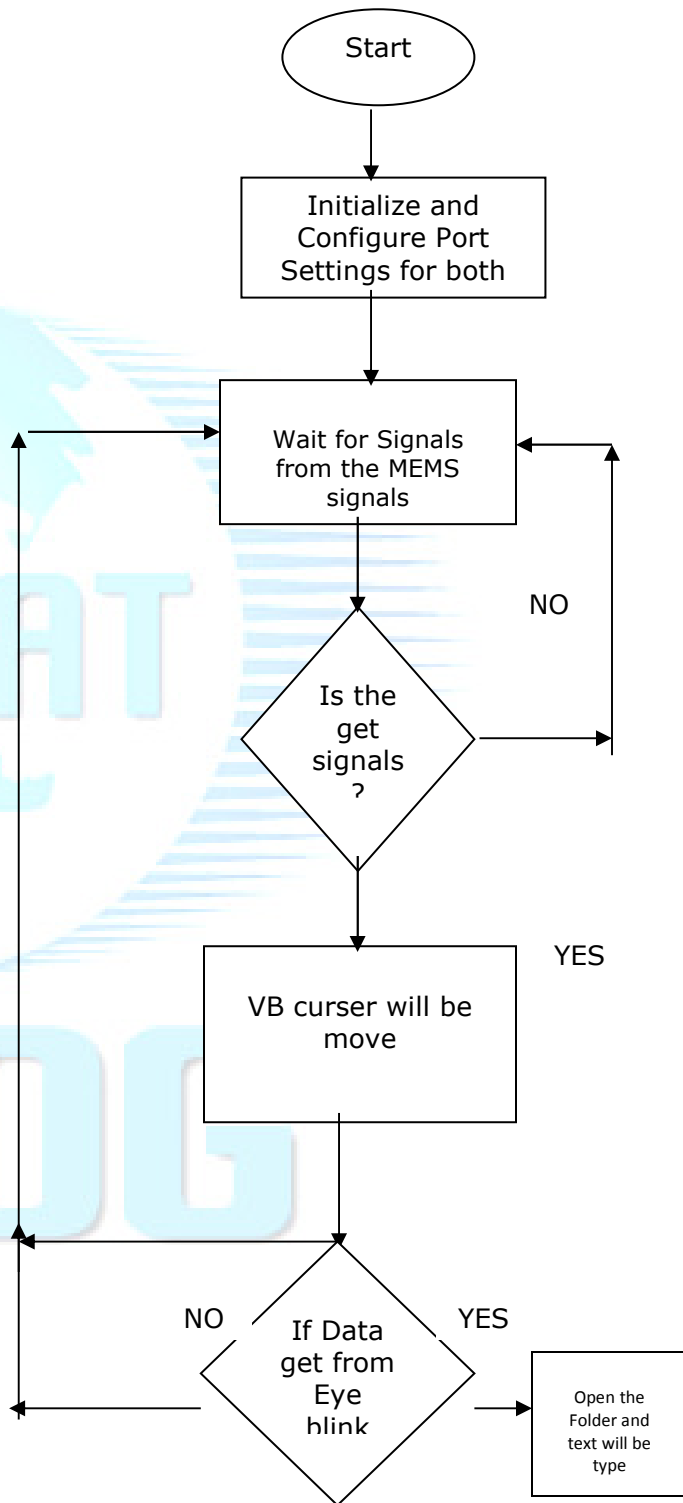

Matlab:

MATLAB (matrix laboratory) is a numerical computing environment and fourth-generation programming language. Developed by MathWorks, MATLAB allows matrix manipulations, plotting of functions and data, implementation of algorithms, creation of user interfaces, and interfacing with programs written in other languages, including C, C++, Java, and Fortran.

Although MATLAB is intended primarily for numerical computing, an optional toolbox uses the MuPAD symbolic engine, allowing access to symbolic computing capabilities. An additional package, Simulink, adds graphical multi-domain simulation and Model-Based Design for dynamic and embedded systems.

In 2004, MATLAB had around one million users across industry and academia.[2] MATLAB users come from various backgrounds of engineering, science, and economics. MATLAB is widely used in academic and research institutions as well as industrial enterprises.

Figure 5. Flowchart for wireless mouse

CONCLUSION

In this work, we tested the effectiveness of pointing and scrolling using MEMS sensor on wireless device interfaces. The results indicate that pointing and scrolling can be effectively done using tilting. Fitts' law is found to fit the experimental data for both of the tasks but with higher coefficient of determination, R^2 , in the case of scrolling. The results also showed that wrist tilting is relatively easier around the thumb than along it. We think that tilting interaction provides an alternative way of interaction that needs only one hand rather than both hands compared to using the stylus. We noted that users prefer tilting using their non dominant hand, which make the dominant hand free for handling the environment. The result introduced in this work can help in the design of device interfaces especially when only one hand is available for the interaction

REFERENCES

- [1]. P. Eslambolchilar and R. Murray-Smith (2004). Tilt-based Automatic Zooming and Scaling in mobile devices-a state space Implementation. In S. A. Brewster and M. D. Dunlop, Editors, Mobile Human-Computer Interaction-MobileHCI 2004: 6th International Symposium, volume 3160 of Lecture Notes in Computing Science, pages 120–131, Glasgow, Scotland, September 2004. Springer-Verlag
- [2] K. Hinckley, E. Cutrell, S. Bathiche, T. Muss (2002). Quantitative analysis of scrolling techniques. In Proceedings of the SIGCHI Conference on Human Factors in Computing Systems: Changing Our World, Changing Ourselves (Minneapolis, Minnesota, USA, April 20 - 25, 2002). CHI '02. ACM, New York, NY, 65-72. DOI=<http://doi.acm.org/10.1145/503376.503389>
- [3] Shijin Dai, Xiaorong Jing and Lenin Li, "Research and analysis on routing protocols for wireless sensor networks," 2005 International Conference on Communications, Circuits and Systems, Vol. 1, 27-30, May 2005.
- [4] LI Jian-Zhong, LI Jin-Bao and SHI Sheng-Fei, "Concepts, Issues and Advance of Sensor Networks and Data Management of Senso networks", Journal of Software, Vol.14, No.10, October 2003.
- [5] Dacfe Dzong, Mario Crevatin, Security for Industrial Communication Systems, 2005 Proceedings of the IEEE.